

UltraSIL™ Polymer-Housed Evolution™ (10 kA) IEEE® Surge Arresters for MV Systems to 36 kV



General

Eaton set the standard for design, manufacturing and delivery of polymeric distribution arresters with its Cooper Power™ series UltraSIL™ polymer-housed arrester family. The UltraSIL polymer-housed Evolution™ surge arrester from Eaton's Cooper Power series product-line incorporates the industry recognized superior polymer-housing material – silicone rubber.

The Evolution surge arrester uses specially formulated and highly durable Metal Oxide Varistors (MOVs) in combination with a proprietary insulating ceramic ring assembly. The mating of these two proven technologies allows Eaton to offer a distribution class arrester with riser-pole protective characteristics and infinite TOV capability. The Evolution surge arrester offers significant improvements in protective characteristics and 60 Hz temporary over voltage (TOV) capability for all common over-head and riser-pole applications.

Construction

The patented construction of the Evolution surge arrester comprises the arrester module assembly encapsulated in a high-strength composite matrix insulating material. The components of the arrester module assembly consist of Metal Oxide Varistors (MOVs) in series with a proprietary insulating ceramic ring assembly. The insulating ceramic ring assembly withstands system voltage during steady state conditions and reduces electrical stress across the MOV disks.

The components of the arrester module assembly are encapsulated on our fully automated assembly line using strict quality control processes. The composite matrix is cured to the arrester module assembly to form a solid insulation system, which is then inserted and bonded to the industry leading track resistant UltraSIL polymer-housing material.

The composite-bonded module assembly provides a secondary moisture seal underneath the primary seal of the UltraSIL polymer-housing material. The combinations of these technologies allow the Evolution surge arrester to be impervious to moisture and capable of withstanding extreme electrical, environmental and cantilever load conditions. The composite wrapped module assembly used in the Evolution surge arrester represents a quantum leap in polymer arrester technology.

Following assembly, each arrester is subjected to a battery of electrical tests to assure the highest quality and in-service field performance.

EATON

Powering Business Worldwide

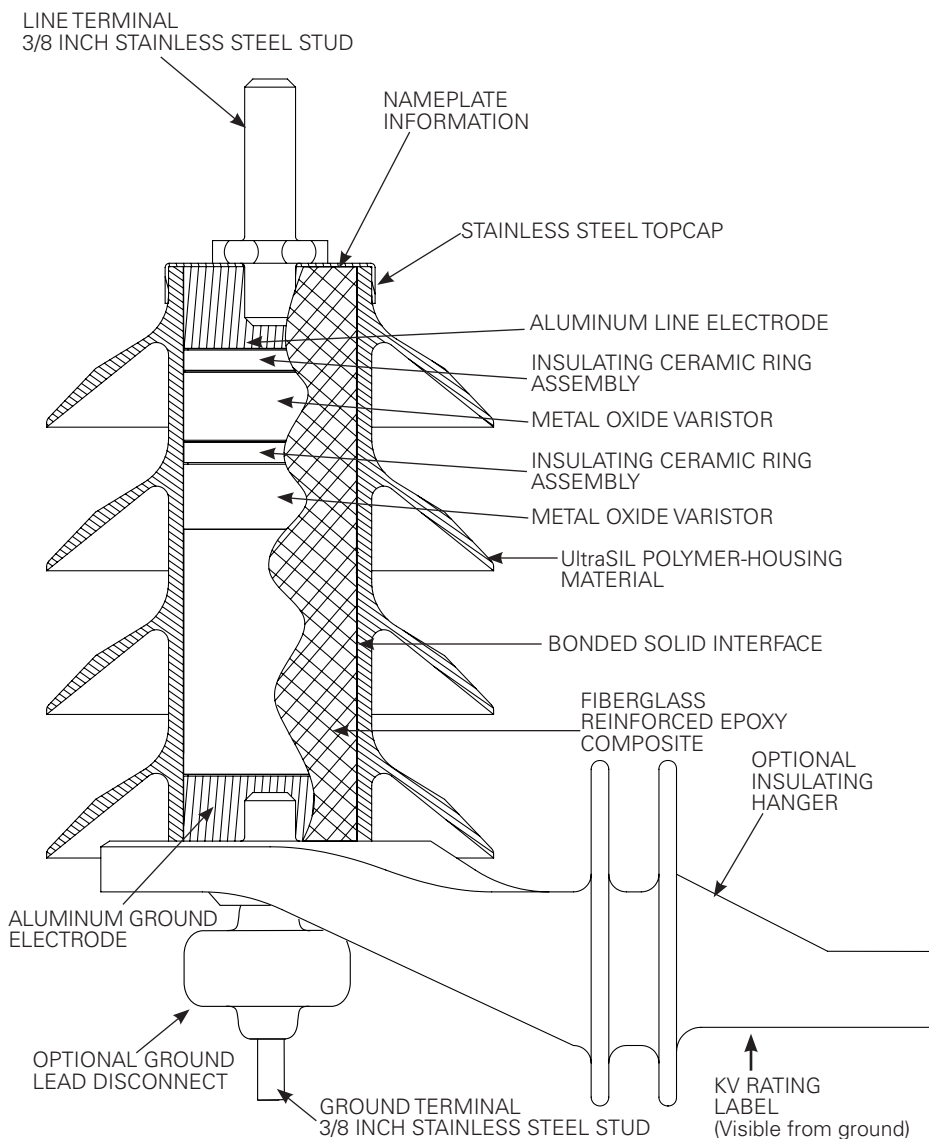

Figure 1. Cutaway illustration of the Evolution Distribution Surge Arrester.

Features

The Evolution surge arrester exceeds protective levels offered by standard metal oxide varistor arresters and helps compensate for two variables related to installation practices and equipment protection:

- Excessive Lead Length
- Aged Equipment Insulation

UltraSIL polymer-housing material has undergone a wide range of design tests to determine the optimum shed configuration. In addition, long term environmental testing has verified the lifetime superiority of silicone rubber when compared to other polymeric insulating materials.

Independent laboratory tests have verified the superiority of polymer-housing material in terms of non-wetting surfaces, resistance to UV degradation and surface tracking, performance in contaminated

environments, chemical inertness, temperature stability and other important insulating properties. UltraSIL polymer-housing material will not support biological growth (algae and mildew), is non-flammable and will not support combustion.

An optional insulated mounting hanger is available to allow connecting to a wide variety of brackets. The insulated hanger, made of glass-filled polyester, has been designed to provide needed mechanical strength for installation and severe loading conditions.

A ground lead isolator is also available. The isolator removes the ground terminal from the arrester in the unlikely event of arrester failure, thus preventing a permanent system fault. An isolator that has operated gives visual indication of internal damage to the arrester and the need for arrester replacement. See Figure 2 for the isolator operating characteristics.

An optional universal wildlife protector has two self-adjusting "valve" style openings which vary from 0 to 0.75" in diameter, thus allowing for a large variety of conductor/insulation sizes while providing optimum wildlife protection. (See page 12, Figure 8 for a dimensional diagram.)

Customers looking to improve system reliability by minimizing wildlife related outages now have multiple options. In addition to the universal wildlife protector, Eaton's Cooper Power series also offers the more robust line terminal wildlife guard. The line terminal wildlife guard is easily retrofitted to existing arrester installations and provides increased electrical insulation for the high voltage terminal of the arrester. The flexible design of the line terminal wildlife guard allows insertion of the lead wire through the bottom of the integral molded flanges. The access holes molded above the flanges will allow conductor sizes ranging from 0 to 0.50" in diameter (OD). The line terminal wildlife guard's geometry allows water to shed away from the surface area of the animal guard while minimizing ice buildup and maintaining flexibility through extreme operating temperatures. See Figure 9 for a dimensional diagram.

For complete wildlife resistance, the ground terminal wildlife guard can easily be installed alongside the line terminal wildlife guard or universal wildlife protector. The ground terminal wildlife guard is a compact and economical guard that ensures wildlife is unable to come in contact with energized objects while on a grounded surface. See Figure 10 for a dimensional diagram.

Operation

The operation of Evolution surge arresters differs from conventional metal oxide arresters. During steady-state conditions, the insulating ceramic ring assembly withstands system voltage while reducing electrical stress on the MOV disks. When surges occur, the insulating ceramic ring assembly sparks over, leaving only the MOV disks in the circuit. The result is much lower discharge voltages as compared to standard heavy duty and riser pole metal oxide arresters. The added insulating ceramic ring assembly extends TOV capability for levels up to 1.78 P/U forever. Improving the Evolution surge arrester's resistance to overvoltage conditions reduces system maintenance related to arresters and helps improve system reliability.

Design testing

The housing material, internals and hardware work together as a system and must stand up to years of exposure to environmental extremes. To assure a superior level of performance, both the components and assembled arrester units have been subjected to a program of testing that accurately simulates years of exposure to actual field conditions. Testing includes:

IEEE Std C62.11™ standard testing – Full certification to performance requirements by an independent laboratory. Reference CP0804, *UltraSIL Polymer-Housed Evolution Surge Arrester Certified Test Report* for details. Additional reference documents are listed on page 14.

To demonstrate the resistance of a composite wrapped module to moisture ingress Eaton performed the Water Immersion Test on the Evolution surge arrester without the polymer-housing material. This test was completed in accordance with IEEE Std C62.11™-2005 standard, Section 8.22, and IEC 60099-4, Ed 2 2004. The arrester sample passed the test by demonstrating less than 5% change in residual voltage, less than 20% change in power loss, less than 10pC of internal partial discharge with no signs of physical damage. A test report is available upon request.

Production tests

A complete production test program ensures a quality product. Each metal oxide varistor receives a series of electrical tests. Quality is demonstrated by a series of destructive tests performed on every batch of varistors. Listed are the production tests performed on the varistors:

- 100% Physical Inspection
- 100% Discharge Voltage test
- 100% V1mA/cm²
- 100% Leakage Current at 80% of V1mA/cm² Voltage
- Batch High-current, Short-duration test
- Batch Thermal Stability test
- Batch Aging test

Each fully assembled arrester must pass the following production tests:

- 100% Physical Inspection
- 100% Partial Discharge Inception Voltage test
- 100% 60 Hz Sparkover Level test

Table 1. Commonly Applied Voltage Ratings of Evolution Surge Arresters

System Voltage (kV rms)		Recommended Arrester Rating per IEEE Std C62.22™ standard (kV rms)					
		Four-Wire Wye Multi-Grounded Neutral		Three-Wire Wye Solidly Grounded Neutral		Delta and Ungrounded Wye	
Nominal	Maximum	Standard MOV Arrester	URT	Standard MOV Arrester	*URT	Standard MOV Arrester	*URT
2.4	2.54	—	—	—	—	3	3
4.16Y/2.4	4.4Y/2.54	3	3	6	3	6	3
4.16	4.4	—	—	—	—	6	3
4.8	5.08	—	—	—	—	6	6
6.9	7.26	—	—	—	—	9	6
8.32Y/4.8	8.8Y/5.08	6	6	9	6	—	—
12.0Y/6.93	12.7Y/7.33	9	9	12	9/10	—	—
12.47Y/7.2	13.2Y/7.62	9	9	15	9/10	—	—
13.2Y/7.62	13.97Y/8.07	10	10	15	10	—	—
13.8Y/7.97	14.52Y/8.38	10	10	15	10	—	—
13.8	14.52	—	—	—	—	18	10
20.78Y/12.0	22Y/12.7	15	15	21	15	—	—
22.86Y/13.2	24.2Y/13.87	18	18	24	18	—	—
23	24.34	—	—	—	—	30	18
24.94Y/14.4	26.4Y/15.24	18	18	27	18	—	—
27.6Y/15.93	29.3Y/16.89	21	21	30	21	—	—
34.5Y/19.92	36.5Y/21.08	27	27	36	27	—	27
46Y/26.6	48.3Y/28	36	36	—	—	—	—

* Recommended arrester ratings for the Evolution arrester for 3-Wire Solidly Grounded Neutral, Delta and Ungrounded Wye circuits are based upon 5% regulation error.

General application recommendations

The rating of an arrester is the maximum power frequency line-to-ground voltage at which the arrester is designed to pass an operating duty-cycle test. Table 1 provides a general application guide for the selection of the proper arrester rating for a given system voltage and system grounding configuration as outlined in the IEEE Std C62.22™ standard application guide.

Under fault conditions and other system anomalies, higher voltages can be experienced by the arrester. To ensure that the arrester ratings will not be exceeded, Eaton application engineers are available to make recommendations. The following information is normally required:

1. System maximum operating voltage.
2. System grounding conditions.
 - A. For four-wire circuits, grounding conditions depend upon whether the system is multi-grounded, whether it has a neutral impedance and whether common primary and secondary neutrals are used.
 - B. For three-wire circuits, grounding conditions depend upon whether the system is solidly grounded at the source, grounded through neutral impedance at the source transformers or ungrounded.

Consult your Eaton representative to have your individual system application needs studied.

Performance test characteristics

Evolution distribution class surge arresters withstand the following design tests as described by IEEE Std C62.11™ standard:

- **Duty Cycle:**
22 current surges of 10 kA crest, 8/20 μs waveshape.
- **High-Current, Short-Duration Discharge:**
2 current surges of 100 kA crest, 4/10 μs waveshape.
- **Low-Current, Long-Duration Discharge:**
20 current surges of 250 A crest 2000 μs duration rectangular wave.

Following each of these tests, the arresters remain thermally stable as verified by:

- Continually decreasing power values during a thirty minute power monitoring period.
- No evidence of physical or electrical deterioration.
- The 10 kA discharge voltages measured after each test changed less than 10% from the initial values.

In addition, **full IEEE Std C62.11™ standard certification has been completed and verified.**

Fault current withstand tests

Fault current withstand tests demonstrate the ability to withstand fault currents for specific durations without expelling any internal components. All Evolution distribution class surge arrester designs have been tested in accordance with the requirements listed in IEEE Std C62.11™ standard, and are non-fragmenting to the levels shown in Table 2.

Table 2. Fault Current Withstand Tests

Fault Current Amplitude (kA rms)	Fault Current Duration (cycles)
0.6	60
20.0	12

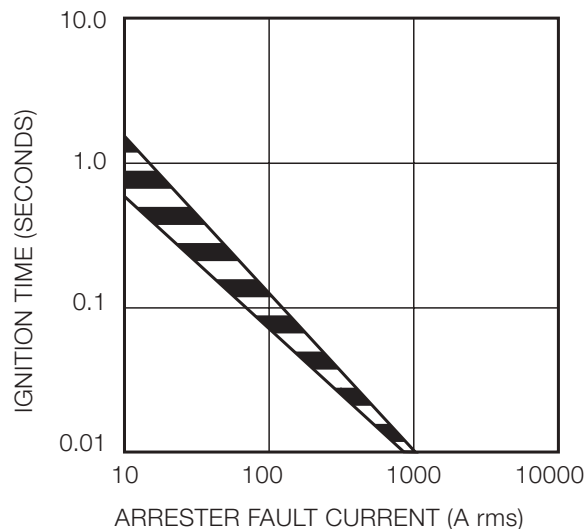

Figure 2. Isolator operating characteristic.

Table 3. Insulation Withstand Characteristics of Optional Insulated Mounting Bracket

Insulated Mounting Bracket	Bracket Mounting Length Center-to-Center (in)	Leakage Distance (in)	Strike (in)	Power Frequency Voltage Withstand (60 sec, Wet, kV)	1.2/50 μ s Impulse (kV Crest)
Standard For Rating 3-10 kV	4.1	5.9	2.8	36	70
Standard For Rating 12-36 kV	5	8.9	3.9	48	80

Dimensions and clearances

Outline drawings for several common design options are shown in Figures 3-6. Dimensions for these designs are listed in Table 3.

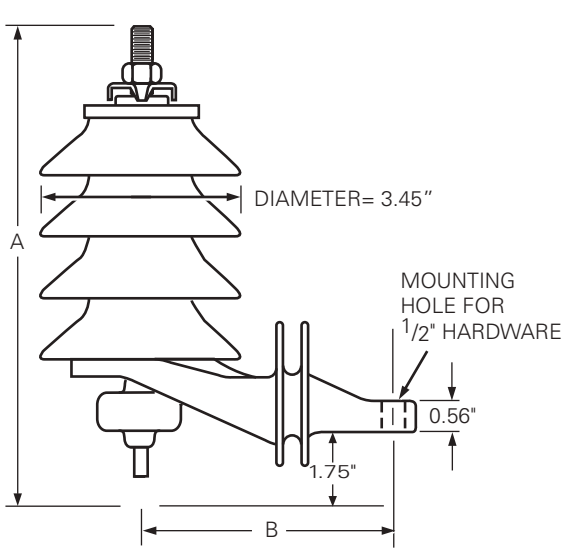

Figure 3. Evolution surge arrester with isolator and insulated hanger.

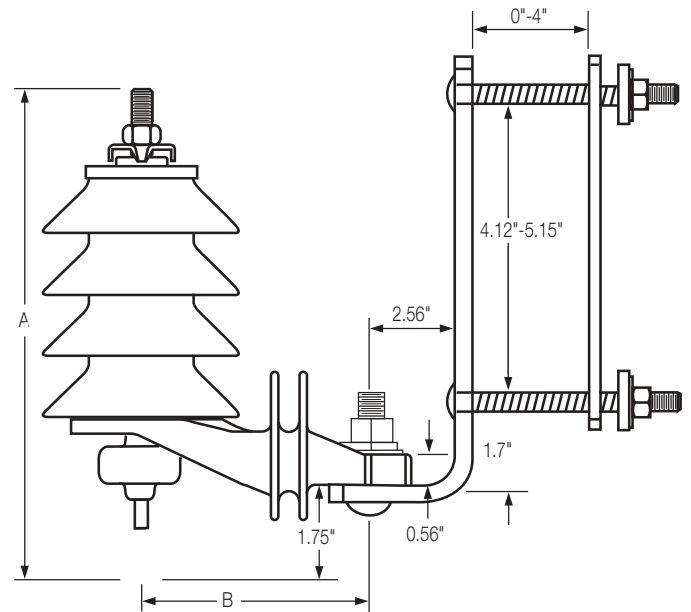

Figure 4. Evolution surge arrester with isolator, insulated hanger and NEMA[®] cross-arm bracket.

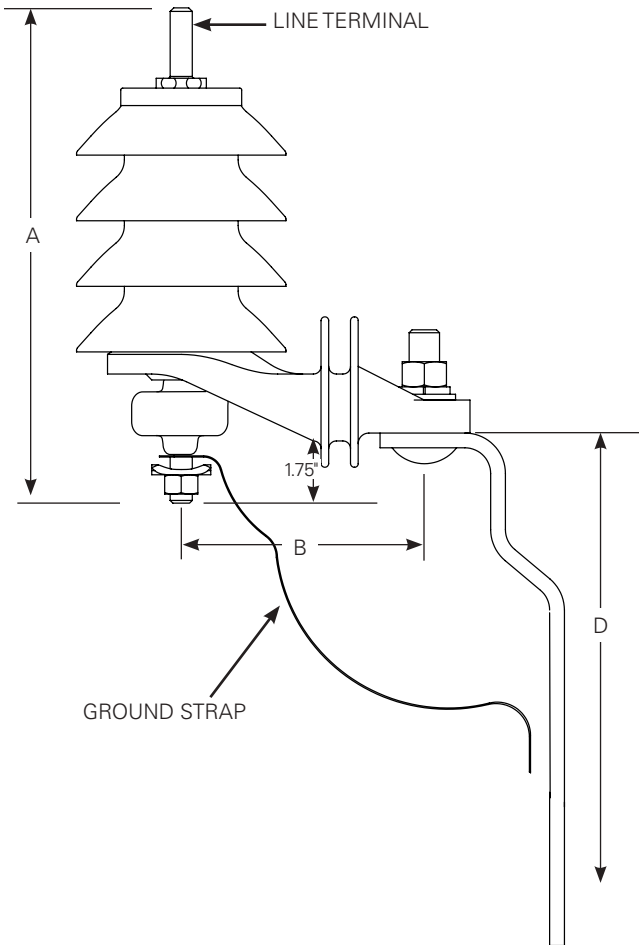

Figure 5. Evolution surge arrester with isolator, insulated hanger and transformer mounting bracket.

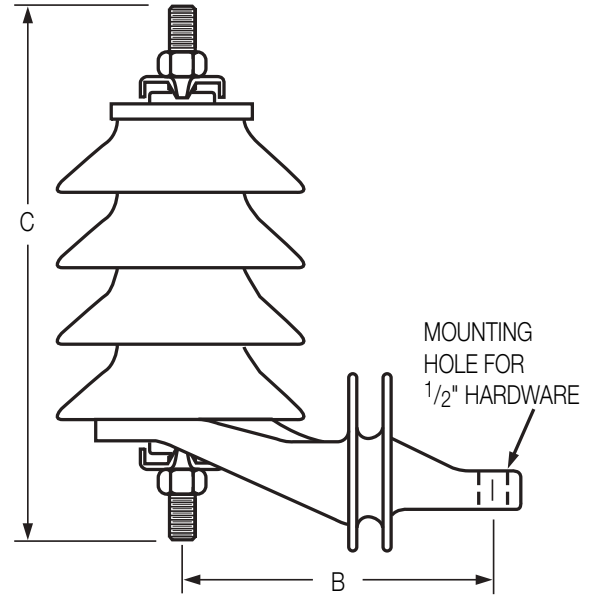

Figure 6. Evolution surge arrester without isolator including insulated hanger and NEMA[®] cross-arm bracket.

Table 4. Dimensional Data – Evolution Surge Arresters

Arrester Rating (kV rms)	Standard Housing Code (Digits 6 & 7, Table 8)	Dimensions Figures 3-6 (Inches)				Minimum Recommended Clearances* (in.)	
		A+	B	C+	D	Phase-to-Ground	Phase-to-Phase
3	04	7.9	4.1	6.5	8.7	3.00	4.25
6	05	9.0	4.1	7.6	8.7	4.00	5.50
9	05	9.0	4.1	7.6	8.7	5.25	7.00
10	05	9.0	4.1	7.6	8.7	5.25	7.00
12	07	11.1	5.0	9.7	8.7	6.00	7.75
15	07	11.1	5.0	9.7	8.7	6.75	8.75
18	08	12.2	5.0	10.8	8.7	9.25	11.25
21	09	13.2	5.0	11.8	8.7	9.25	11.25
24	10	14.3	5.0	12.9	8.7	10.75	13.25
27	11	15.3	5.0	13.9	14.3	10.75	13.25
30	12	16.4	5.0	15.0	14.3	10.75	13.25
33	13	17.5	5.0	16.1	14.3	12.75	16.25
36	14	18.5	5.0	17.1	14.3	12.75	16.25

* All clearances are measured from center line of arrester per IEEE Std C62.22™ standard.

+ With optional Wildlife Protector add 0.2 inches.

Insulation characteristics

The insulation characteristics of the Evolution surge arrester family are shown in Table 5.

Table 5. Housing Insulation Withstand Voltages of Evolution Surge Arresters

Arrester Housing Code (Digits 6 & 7)	Creep Distance (in.)		1.2/50 μ s Impulse 1 min. Wet (kV rms)			1.2/50 μ s Impulse 1 min. Dry (kV rms)			1.2/50 μ s Impulse 1 min. Wet (kV rms)			1.2/50 μ s Impulse 1 min. Dry (kV rms)			1.2/50 μ s Impulse 1 min. Wet (kV rms)			1.2/50 μ s Impulse 1 min. Dry (kV rms)			
	Distance	Strike	(kV crest)	Dry (kV rms)	10 sec. Wet (kV rms)	(kV crest)	Dry (kV rms)	10 sec. Wet (kV rms)	(kV crest)	Dry (kV rms)	10 sec. Wet (kV rms)	(kV crest)	Dry (kV rms)	10 sec. Wet (kV rms)	(kV crest)	Dry (kV rms)	10 sec. Wet (kV rms)	(kV crest)	Dry (kV rms)	10 sec. Wet (kV rms)	
04	10.1	4.2	91	56	36	105	55	39	79	52	34	99	56	39	82	51	33				
05	13.0	5.2	104	64	45	117	63	52	89	55	44	109	60	52	90	62	46				
06	15.9	6.3	117	78	57	126	86	59	93	61	58	119	80	59	97	72	56				
07	18.8	7.3	129	87	68	137	96	71	98	62	59	122	81	63	107	81	69				
08	21.7	8.4	140	96	79	148	106	83	104	65	61	126	82	67	118	89	81				
09	24.6	9.4	152	105	89	159	116	94	110	68	63	130	83	72	129	98	93				
10	27.5	10.5	164	114	100	171	126	105	117	72	67	136	86	78	140	106	105				
11	30.4	11.5	176	123	110	183	135	116	125	77	71	142	90	83	152	114	116				
12	33.3	12.6	189	131	120	195	144	127	133	82	75	149	94	89	164	122	126				
13	36.2	13.6	201	139	130	207	153	137	142	88	81	158	99	96	177	130	136				
14	39.1	14.7	215	148	140	220	161	147	152	94	87	167	105	102	190	138	145				
15	42.0	15.8	228	155	150	233	170	157	162	101	93	177	112	109	204	146	153				
16	44.9	16.8	242	183	158	246	178	167	173	109	101	187	120	117	218	154	162				
17	47.8	17.8	255	171	169	259	185	176	185	117	109	199	128	125	233	161	169				

Protective characteristics

Evolution distribution class surge arresters provide excellent overvoltage protection for electrical equipment throughout distribution systems. The protective characteristics of the Evolution surge arrester are shown in Table 6.

Table 6. Protective Characteristics – Evolution Surge Arrester Heavy Duty (URT)

Arrester Rating (kV rms)	MCOV (kV rms)	Minimum 60 Hz Sparkover (kV crest/ $\sqrt{2}$)	Front-of-wave Protective Level* (kV crest)	3rd Party Front-of-Wave Protective Level** (kV crest)	Maximum Discharge Voltage (kV crest)						Switching Surge kV Crest
					1.5 kA	3 kA	5 kA	10 kA	20 kA	40 kA	
3	2.55	4.54	20.0	—	8.1	8.7	9.3	10.2	11.6	13.5	7.6
6	5.10	9.08	23.0	—	16.1	17.4	18.6	20.3	23.3	27.0	15.2
9	7.65	13.6	32.4	—	18.9	20.3	21.8	23.8	27.3	31.6	17.8
10	8.40	15.0	32.4	24.3	20.1	21.6	23.2	25.4	29.0	33.7	19.0
12	10.2	18.2	52.4	—	25.2	27.2	29.1	31.8	36.4	42.2	23.8
15	12.7	22.6	55.4	—	30.5	32.8	35.2	38.5	44.0	51.1	28.8
18	15.3	27.2	64.8	51.1	37.8	40.8	43.7	47.8	54.6	63.4	35.7
21	17.0	30.3	64.8	—	40.1	43.2	46.3	50.6	57.9	67.2	37.8
24	19.5	34.7	87.8	—	46.4	50.0	53.6	58.6	67.0	78	43.8
27	22.0	39.2	97.2	66.9	53.9	58.0	62.2	68.0	78	90	50.8
30	24.4	43.4	117.2	—	58.6	63.2	67.7	74	85	98	55.3
33	27.0	48.1	120.2	—	66.6	71.7	77	84	96	112	62.8
36	29.0	51.6	129.6	—	70.4	76	81	89	102	118	66.4

* The Front-of-Wave Protective Level is the larger of the Front-of-Wave Sparkover Voltage (FOW) or Equivalent Front-of-Wave Discharge Voltage (EFOW) per IEEE Std. C62.11-2005 standard. The Front-of-Wave Sparkover Level is based on a voltage waveform having a rate of rise of 100 kV/ μ s for each 12 kV of arrester duty cycle rating. The EFOW is a discharge voltage resulting from a 10 kA current impulse cresting in 0.5 μ s. The Front-of-Wave Protective Level for the Evolution arrester is the FOW Sparkover Level.

** The 3rd Party test report CP1012 is available on www.eaton.com/cooperpowerseries website and includes test data for standard production 10 kV, 18 kV & 27 kV arresters.

**UltraSIL Housed EVOLUTION Arrester
TOV Curve Per ANSI C62.11**

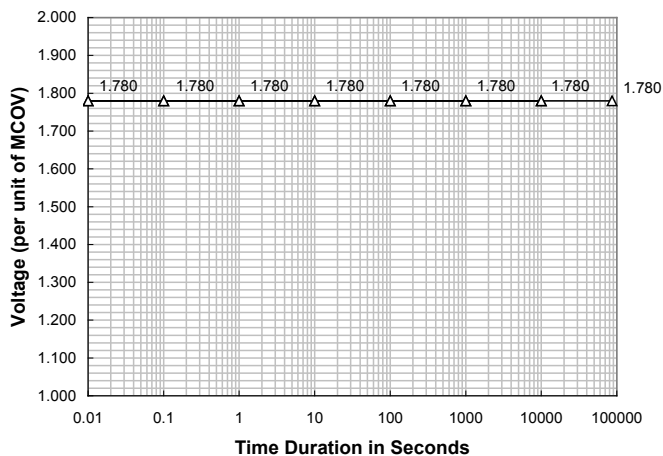

Figure 7. Temporary overvoltage curve. No prior duty – 60° C ambient.

Ordering information

Evolution surge arresters can be ordered in a variety of customer defined options. Table 7 below lists standard part numbers for our most common design options (see illustrations on pages 5-6, Figures 3-6). For other design options, use Table 8 to customize the arrester to specific needs. For further options contact your Eaton sales engineer.

Temporary overvoltage (TOV) capability

The ability to withstand 60 Hz overvoltage conditions [Temporary Overvoltage (TOV)] is shown in Figure 7 for all Evolution distribution-class surge arresters. The graph shows for a given voltage magnitude (on a Per Unit of MCOV basis) the time an arrester can survive a TOV condition without going into thermal runaway.

Table 7. Catalog Numbers-Evolution Distribution Class Surge Arresters

Arrester Rating (kV rms)	With Isolator and Insulated Hanger (Figure 3)	With Isolator, Insulated Hanger and NEMA Cross-Arm Bracket (Figure 4)	With Isolator, Insulated Hanger and Transformer Mounting Bracket (Figure 5)	With Insulating Hanger Without Isolator (Figure 6)
3	URT03040A1A1A1A	URT03040A1A1B1A	URT03040A1C1C1C	URT03040A0A1A1A
6	URT06050A1A1A1A	URT06050A1A1B1A	URT06050A1C1C1C	URT06050A0A1A1A
9	URT09050A1A1A1A	URT09050A1A1B1A	URT09050A1C1C1C	URT09050A0A1A1A
10	URT10050A1A1A1A	URT10050A1A1B1A	URT10050A1C1C1C	URT10050A0A1A1A
12	URT12070A1A1A1A	URT12070A1A1B1A	URT12070A1C1C1C	URT12070A0A1A1A
15	URT15070A1A1A1A	URT15070A1A1B1A	URT15070A1C1C1C	URT15070A0A1A1A
18	URT18080A1A1A1A	URT18080A1A1B1A	URT18080A1C1C1C	URT18080A0A1A1A
21	URT21090A1A1A1A	URT21090A1A1B1A	URT21090A1C1C1C	URT21090A0A1A1A
24	URT24100A1A1A1A	URT24100A1A1B1A	URT24100A1C1C1C	URT24100A0A1A1A
27	URT27110A1A1A1A	URT27110A1A1B1A	URT27110A1C1C1C	URT27110A0A1A1A
30	URT30120A1A1A1A	URT30120A1A1B1A	URT30120A1C1C1C	URT30120A0A1A1A
33	URT33130A1A1A1A	URT33130A1A1B1A	URT33130A1C1C1C	URT33130A0A1A1A
36	URT36140A1A1A1A	URT36140A1A1B1A	URT36140A1C1C1C	URT36140A0A1A1A

Note: Digits 2 & 3 Options "RT" replaces Normal-Duty, Heavy-Duty & Riser-Pole.

Note: All catalog numbers listed above include a universal wildlife protector; catalog number AV346X1.

Table 8. UltraSIL Polymer-Housed Evolution Distribution-Class Surge Arrester UltraQUICK Catalog Numbering System



Catalog Number Digits:

1 = UltraSIL Polymer-Housed Arrester: **U**

2 & 3 = Arrester Class: **RT** = Evolution

4 & 5 = Arrester Rating (MCOV):
03 = 3 kV (2.55 kV) **12** = 12 kV (10.2 kV) **21** = 21 kV (17.0 kV) **30** = 30 kV (24.4 kV)
06 = 6 kV (5.1 kV) **15** = 15 kV (12.7 kV) **24** = 24 kV (19.5 kV) **33** = 33 kV (27.0 kV)
09 = 9 kV (7.65 kV) **18** = 18 kV (15.3 kV) **27** = 27 kV (22.0 kV) **36** = 36 kV (29.0 kV)
10 = 10 kV (8.4 kV)

6 & 7 = Housing Code per Arrester Rating: Select from Table below.

★ = Standard Creepage Housing ○ = Optional Creepage Housings

Digits 6 & 7	04	05	06	07	08	09	10	11	12	13	14	15	16	17
Leakage Distance (in.)	10.1	13.0	15.9	18.8	21.7	24.6	27.5	30.4	33.3	36.2	39.1	42.0	44.9	47.8
Arrester Rating (kV rms)														
3	★													
6		★	○											
9		★	○	○	○									
10		★	○	○	○									
12				★	○	○	○							
15				★	○	○	○	○						
18					★	○	○	○	○					
21						★	○	○	○	○	○			
24							★	○	○	○	○			
27								★	○	○	○	○		
30									★	○	○	○	○	
33										★	○	○	○	○
36											★	○	○	○

8 = Line Terminal Wire: **0** = No Line Terminal Wire

1 = 12", #6 AWG Insulated Wire, Stripped 1.25" both ends

4 = 18", #6 AWG Insulated Wire, Stripped 1.25" both ends

7 = 30", #6 AWG Insulated Wire, Stripped 1.25" both ends

2 = 12", #6 AWG Insulated Wire, 1 ring terminal/1 end stripped 1.25"

5 = 18", #6 AWG Insulated Wire, 1 ring terminal/1 end stripped 1.25"

8 = 30", #6 AWG Insulated Wire, 1 ring terminal/1 end stripped 1.25"

3 = 12", #6 AWG Insulated Wire, 2 ring terminals

6 = 18", #6 AWG Insulated Wire, 2 ring terminals

9 = 30", #6 AWG Insulated Wire, 2 ring terminals

9 = Line Terminal Options

<p>A = Silicon Bronze Nut, Stainless Steel Wire Clamp & Universal Wildlife Protector. Reference Figure 8 for dimensional information.</p>	<p>B = Silicon Bronze Nut & Stainless Steel Wire Clamp</p>	<p>C = No Hardware</p>	<p>D = Silicon Bronze Nut, Lock Washer, Flat Washer & Universal Wildlife Protector (For leads with ring terminals) Reference Figure 7 for dimensional information.</p>	<p>K = Silicon Bronze Nut, Stainless Steel Wire Clamp</p>	<p>X = Silicon Bronze Nut, Stainless Steel Wire Clamp and line terminal wildlife guard. Reference Figure 9 for dimensional information.</p>

Table 8. UltraSIL Polymer-Housed Evolution Distribution-Class Surge Arrester UltraQUIK Catalog Numbering System (continued)

1	2	3	4	5	6	7	8	9	10	11	12	13	14	15
U	R	T												

10 = Isolator, with 3/8" stainless steel grounding stud

0 = No Isolator

2 = Red Isolator

4 = Blue Isolator



6 = Orange Isolator

1 = Black Isolator (**Standard**)

3 = Yellow Isolator

5 = White Isolator

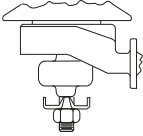
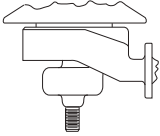
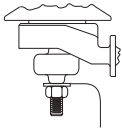
11 = Ground Terminal Options

			
A = Stainless Steel Wire Clamp with Silicon Bronze Nut (Shown with optional Isolator and Insulated Hanger)	B = No Hardware (Shown with optional Isolator and Insulated Hanger)	C = Copper Transformer Grounding Strap with Stainless Steel Lock Washer & Silicon Bronze Nut (Shown with optional Isolator and Insulated Hanger)	D = Stainless Steel Washer, Lock Washer, Silicon Bronze Nut

12 = Base Configuration Options

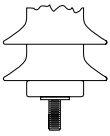
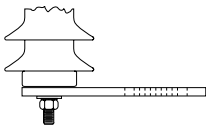
		
0 = Insulated Base (Base Mounted Arrester)	1 = Insulated Hanger (Required with optional isolator) (Available only if Digits 6 & 7 are Housing Options 15 or less*) * For more information, contact your Eaton representative.	2 = Insulated Base With Conductive Mounting Strap (Requires "D" in Digit 11)

13 = Mounting Bracket Options

			
A = Without an Additional Mounting Bracket	B = NEMA [®] Cross-Arm Bracket (Arrester Mounting Hardware Included) (Requires "1" or "2" in Digit 12) (Refer to Figure 11 for dimensional information.)	C = Transformer Bracket (Arrester Mounting Hardware Included) (Requires "1" or "2" in Digit 12) (Refer to Figures 12 and 13 for dimensions by rating.)	D = Option C plus Transformer Mounting Hardware (2 each – 1/2", 13-UNC x 3/4" Bolts, Flat Washers, and Lock Washers) (Requires "1" or "2" in Digit 12) (Refer to Figures 12 and 13 for dimensions by rating.)

Table 8. UltraSIL Polymer-Housed Evolution Distribution-Class Surge Arrester UltraQUIK Catalog Numbering System (continued)

1	2	3	4	5	6	7	8	9	10	11	12	13	14	15
U	R	T												

12 & 13 = Double Digit Mounting Options with Ground Terminal Wildlife Guard

 <p>E8 = Ground Terminal Wildlife Guard, Insulated Hanger (Shown with optional isolator), NEMA® cross-arm bracket (Arrester Mounting Hardware Included) Refer to Figures 10 and 11 for dimensional information</p>	 <p>E9 = Ground Terminal Wildlife Guard, Insulated Hanger (Shown with optional isolator), transformer bracket. Reference Figures 10, 12, and 13 for dimensional information.</p>
--	--

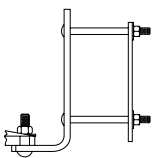
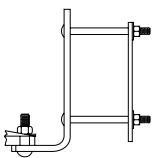
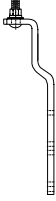
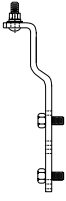
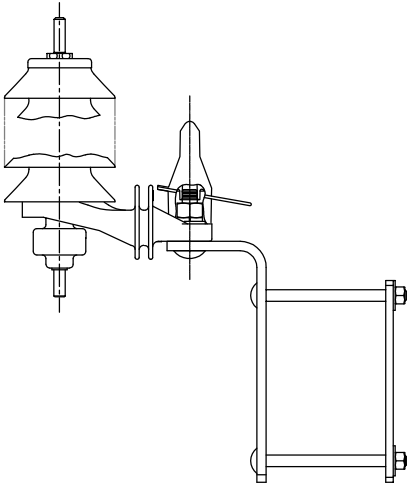
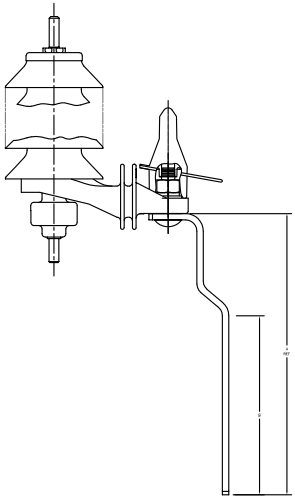
14 = Nameplate Information: 1 = IEEE Std C62.11™ standard Required Data

- 15** = Packaging:
- A** = Individual Carton (Assembled Terminal Hardware). Each arrester is shipped in an individual high strength cardboard carton. The top and bottom terminal hardware is assembled to the arrester. Any optional brackets or hardware are provided unassembled.
 - C** = Bulk Packed (Assembled Terminal Hardware). Pallet sized bulk cardboard packaging for transformer mounting bracket options (Digits 13 = C or D only). Each arrester is shipped fully assembled including transformer mounting bracket. Available for 3-24 kV arresters only. Full pallet quantities only: 3-10 kV = 90, 12-18 kV = 72, 21-24 kV = 40.
 - 3** = **International**, Individual Carton (Assembled Terminal Hardware). Each arrester with accessories is shipped in an individual cardboard carton. The top and bottom terminal hardware is assembled to the arrester. Individual cartons are packed within a heavy duty quadwall carton having a skid bottom and suitable for double stacking within an ocean shipping container.

Available accessories for the Evolution surge arrester

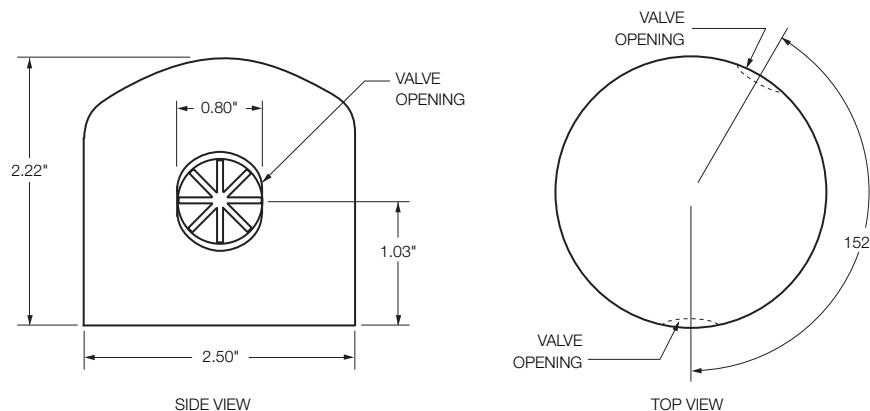

Figure 8. Universal wildlife protector (catalog number AV346X1C).

The optional universal wildlife protector has two self-adjusting "valve" style openings which vary from 0 to 0.75" in diameter, thus allowing for a large variety of conductor/insulation sizes while providing optimum wildlife protection.

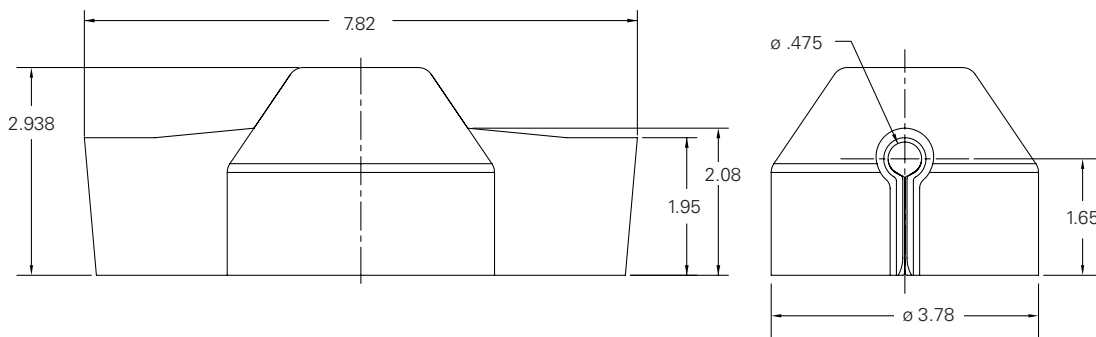

Figure 9. Line terminal wildlife guard (catalog number AV698X1C). (All dimensions in inches.)

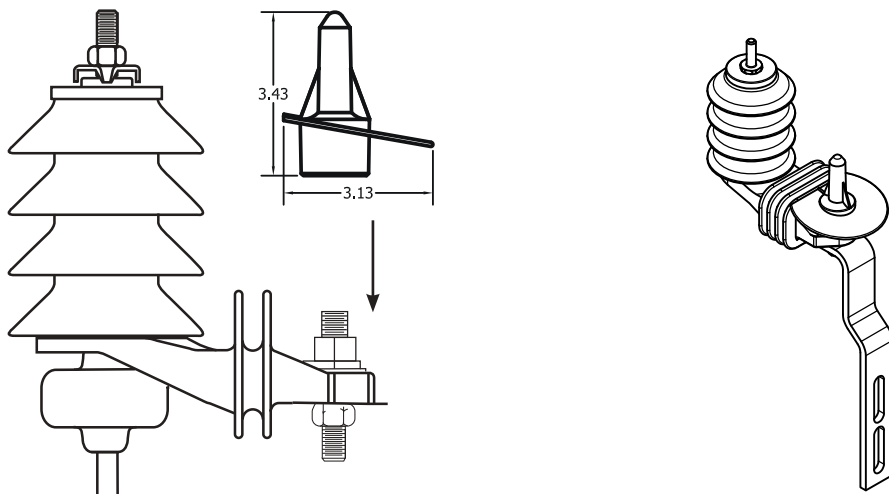

Figure 10. Ground terminal wildlife guard (catalog number AV731X1C). (All dimensions in inches.) Left shows attachment of ground terminal wildlife guard, right images shows ground terminal wildlife guard completely installed.

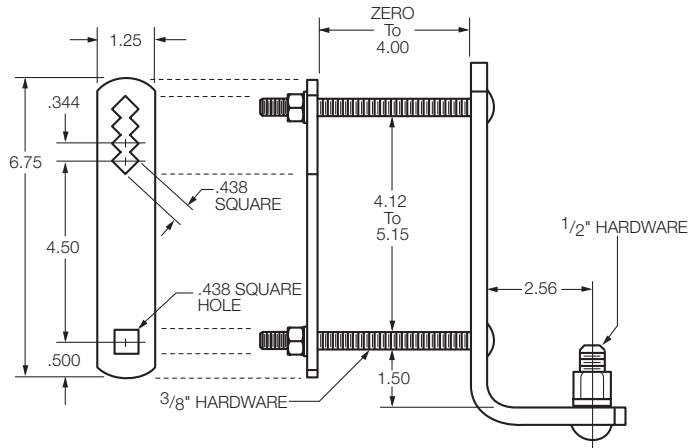

Figure 11. NEMA® cross-arm bracket (catalog number AM35A1). Can be specified with a "B" in digit 13. (All dimensions in inches.)

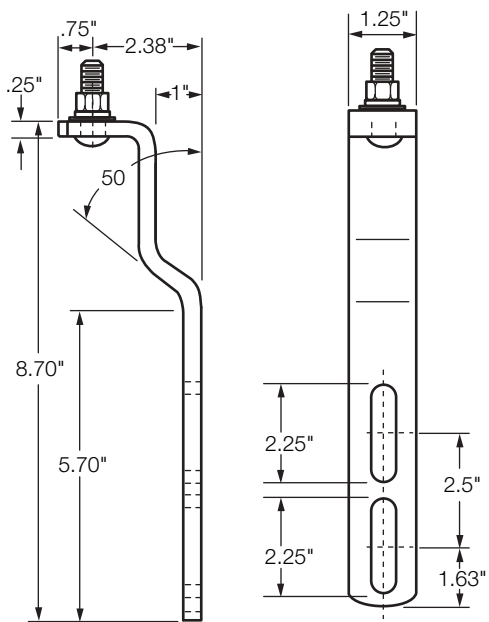

Figure 12. Standard transformer mounting bracket for 3-24 kV arrester (catalog number AM36A2). Can be specified with a "C" in Digit 13. (All dimensions in inches.)

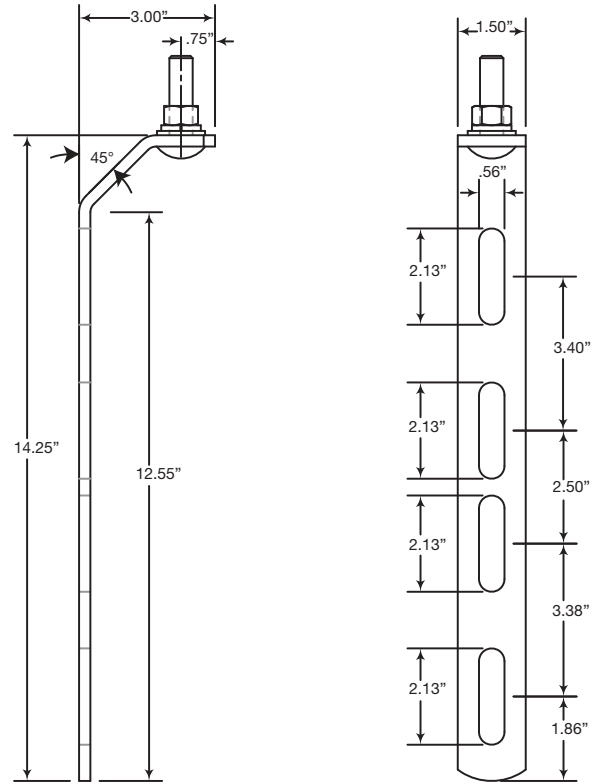

Figure 13. Standard transformer mounting bracket for 27-36 kV arrester (catalog number AH46A2). Can be specified with a "C" in Digit 13. (All dimensions in inches.)

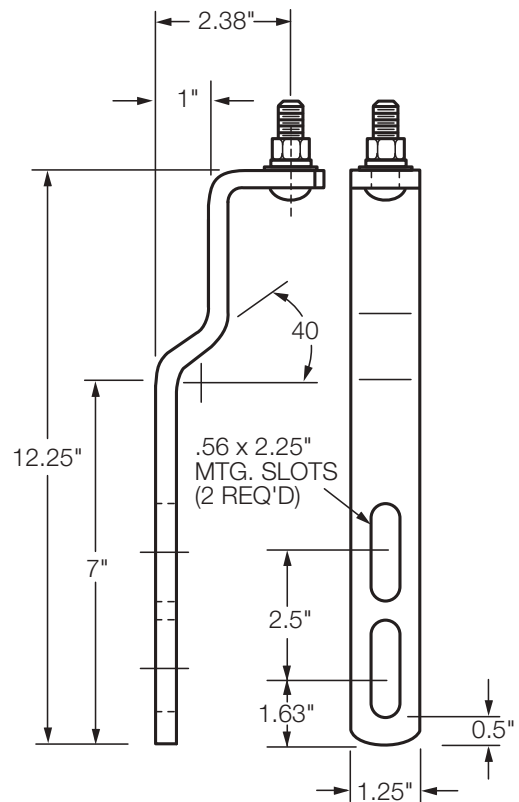

Figure 14. Optional transformer mounting bracket (catalog number AM36A3). Can be specified with an "N" in Digit 13. (All dimensions in inches.)

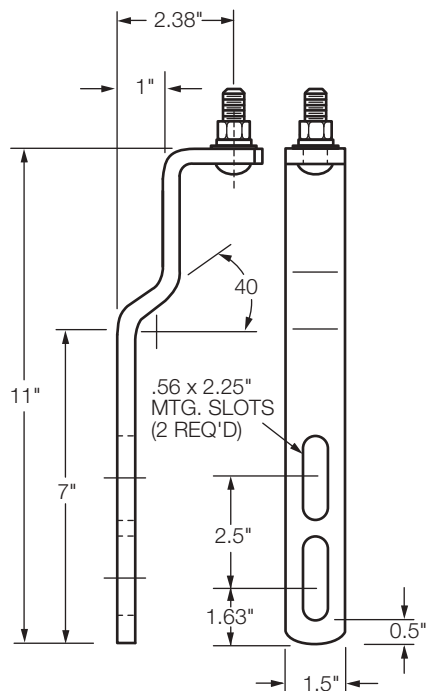

Figure 15. Optional transformer mounting bracket (catalog number AM36A1). Can be specified with an "S" in Digit 13. (All dimensions in inches.)

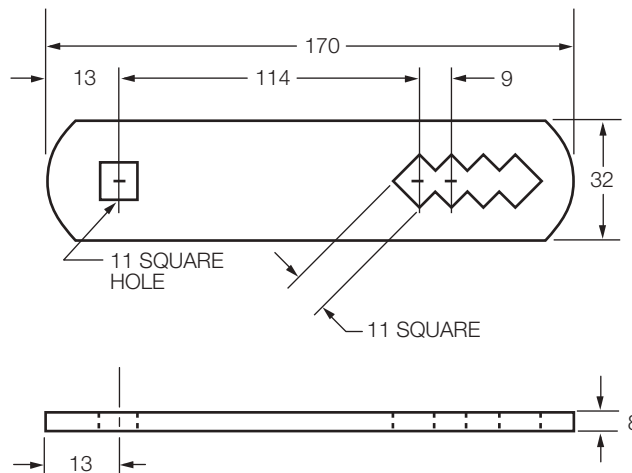

Figure 16. Conductive base mounting for use with 3/8" hardware. Can be specified with a "2" in digit 12. (Requires "0" in digit 10, "D" in digit 11.) (All dimensions in inches.)

Additional information

- MN235006EN, UltraSIL Housed Distribution-Class MOV Arrester Installation Instructions
- B235-08033, Taking Protection to the Extremes, The Evolution Surge Arrester
- B235-08022, Superior Protection for Arresters and Wildlife
- CP0804, UltraSIL Polymer-Housed Evolution Surge Arrester Certified Test Report
- CP1012, UltraSIL Polymer-Housed Evolution Surge Arrester Design Test

Eaton
1000 Eaton Boulevard
Cleveland, OH 44122
United States
Eaton.com

Eaton's Power Systems Division
2300 Badger Drive
Waukesha, WI 53188
United States
Eaton.com/cooperpowerseries

© 2017 Eaton
All Rights Reserved
Printed in USA
Publication No. CA235018EN

Eaton is a registered trademark.

All trademarks are property
of their respective owners.

For Eaton's Cooper Power series
Evolution surge arrester product information
call 1-877-277-4636 or
visit: www.eaton.com/cooperpowerseries.